



swiss lifting solutions

# TECHNICAL DATA GIS - SLEWING JIB CRANES



since  
1957

[www.gis-ag.ch](http://www.gis-ag.ch)



## General information

General information	03
---------------------	----

## Pillar-mounted slewing jib cranes

Pillar-mounted slewing jib cranes GISKB steel hollow profile	04
Pillar-mounted slewing jib cranes GISKB aluminium hollow profile	05
Pillar-mounted slewing jib cranes GSD-TR steel pipe profile	06
Pillar-mounted slewing jib cranes IPE steel profile	07

## Wall-mounted slewing jib cranes

Wall-mounted slewing jib cranes GISKB steel hollow profile	08
Wall-mounted slewing jib cranes GISKB aluminium hollow profile	09
Wall-mounted slewing jib cranes GSD-TR steel pipe profile	10
Wall-mounted slewing jib cranes IPE steel profile	11

## Ceiling-mounted slewing jib cranes

Ceiling-mounted slewing jib cranes GISKB steel hollow profile	12
Ceiling-mounted slewing jib cranes GISKB aluminium hollow profile	12
Ceiling-mounted slewing jib cranes GSD-TR steel pipe profile	13
Ceiling-mounted slewing jib cranes IPE steel profile	13

## Mobile slewing jib cranes

Mobile pillar-mounted slewing jib cranes GISKB steel hollow profile	14
Mobile pillar-mounted slewing jib cranes GISKB aluminium hollow profile	15
Mobile pillar-mounted slewing jib cranes GSD-TR steel pipe profile	16
Mobile pillar-mounted slewing jib cranes IPE steel profile	17

## Miscellaneous

Energy supply	18
Composite technology	19
Special solutions	19

## General information

GIS pillar- and wall-mounted slewing jib cranes offer a simple and functional solution for ergonomic goods handling. Depending on the desired load capacity, the jib working radius and the running properties, aluminium or steel profiles are used.

In combination with a GIS electric chain hoist and a trolley (manual or electric), a GIS vacuum-handling system or another load-handling device, you get a complete crane system from one source - directly from the Swiss manufacturer. GIS slewing cranes are a reasonable addition to a complete materials handling system. The all-purpose application is used for single-user workstations, storage areas, loading ramps or in halls, whenever other handling devices are not suitable due to static reasons.

GIS slewing cranes are differed in pillar- and wall- or ceiling-mounted slewing cranes. The second substantial difference is the crane rail. Depending on the construction conditions and the lifting capacities a GISKB profile, IPE steel profile or a square profile is used for the jib arm. The slewing cranes are optimised to the respective application.

Depending on customised requirements, special solutions can be offered. We revert to a vast range of accessories.

GIS slewing cranes are designed in accordance with the directives of EN 13001 and EN 14985. The associated anchorage systems are designed in accordance with Eurocode EN 1992-4.



# Slewing pillar crane GISKB steel hollow profile

Lifting capacity up to 1000 kg

## Standard version

Pillar and jib primed light grey RAL 7035  
 Slewing range up to 270° stepless (manually)  
 Trolley with smoothly running plastic load wheels  
 Traction limit for trolley  
 With anchorage for minimum C20/C25 concrete strength

## Options:

Coating upon request or hot-dip galvanised  
 Power supply; trailing cable, c-rail or conductor line with main switch (see page 18)  
 Electric moving  
 Mounting options can be found on page 19  
 Special solutions can be found on page 19  
 Construction heights and jib lengths can be adapted individually to customer's needs.  
 GIS electric chain hoist

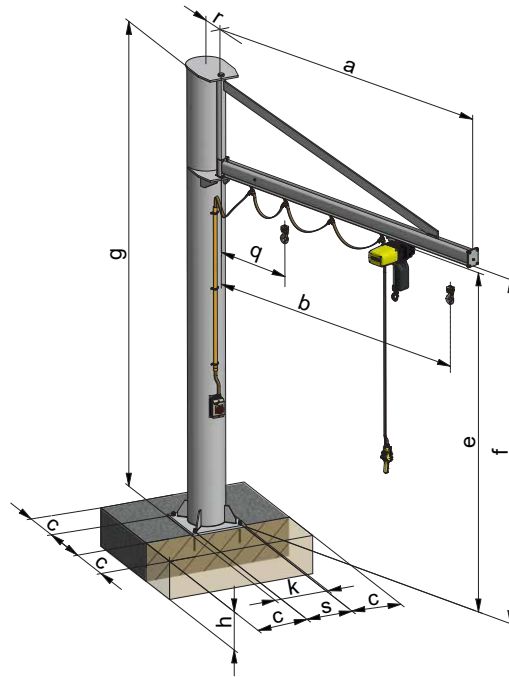

Part number	Capacity kg	Jib arm a mm	Height g mm	f mm	e mm	r mm	q mm	b mm	GISKB	Base plate drill holes mm	s mm	k mm	Minimum edge distance c mm	Min. foundation thickness h mm	Pillar Ø mm	
9311.1000/125/2	125	2000	3800	3300	3265	265	424	1890	I	4 × Ø20	300	400	200	160	273 (Nr. 1)	
9311.1001/125/3		3000					524	2890								
9311.1002/125/4		4000					624	3890								
9311.1006/125/5	5000	4200	300	647	4879	II	4 × Ø20	425	500	250	250	324 (Nr. 2)				
9311.1000/160/2	160	2000	3800	3300	3265	265	424	1890	I	4 × Ø20	300	400	200	160	273 (Nr. 1)	
9311.1001/160/3		3000					524	2890								
9311.1002/160/4		4000					624	3890								
9311.1006/160/5	5000	4200	300	647	4879	II	4 × Ø20	425	500	250	250	324 (Nr. 2)				
9311.1003/200/2	200	2000	3800	3300	3265	265	424	1890	I	4 × Ø20	300	400	200	160	273 (Nr. 1)	
9311.1004/200/3		3000					524	2890								
9311.1005/200/4		4000					647	3879								
9311.1006/200/5	5000	4200	300	647	4879	II	4 × Ø20	425	500	250	250	324 (Nr. 2)				
9311.1003/250/2	250	2000	3800	3300	3265	265	424	1890	I	4 × Ø20	300	400	200	160	273 (Nr. 1)	
9311.1004/250/3		3000					524	2890								
9311.1005/250/4		4000					647	3879								
9311.1006/250/5	5000	4200	300	647	4879	II	4 × Ø20	425	500	250	250	324 (Nr. 2)				
9311.1003/320/2	320	2000	3800	3300	3265	265	424	1890	I	4 × Ø20	300	400	200	160	273 (Nr. 1)	
9311.1004/320/3		3000					524	2890								
9311.1005/320/4		4000					647	3879								
9311.1006/320/5	5000	4200	300	647	4879	II	4 × Ø20	425	500	250	250	324 (Nr. 2)				
9311.1007/400/2	400	2000	3800	3300	3265	265	424	1890	I	4 × Ø20	300	400	200	160	273 (Nr. 1)	
9311.1008/400/3		3000					300	547								2879
9311.1009/400/4		4000					4200	350								647
9311.1010/400/5	5000	4200	350	647	4879	II	6 × Ø20	500	600	250	250	407 (Nr. 3)				
9311.1007/500/2	500	2000	3800	3300	3265	265	424	1890	I	4 × Ø20	300	400	200	160	273 (Nr. 1)	
9311.1008/500/3		3000					300	547								2879
9311.1009/500/4		4000					4200	350								647
9311.1010/500/5	5000	4200	350	647	4879	II	6 × Ø20	500	600	250	250	407 (Nr. 3)				
9311.1011/630/2	630	2000	4200	3300	3265	300	447	1879	II	4 × Ø20	425	500	250	250	324 (Nr. 2)	
9311.1008/630/3		3000					350	547								2879
9311.1009/630/4		4000					350	647								3879
9311.1014/630/5	5000	4200	450	647	4879	II	8 × Ø20	600	700	300	300	508 (Nr. 4)				
9311.1011/800/2	800	2000	4200	3300	3265	300	447	1879	II	4 × Ø20	425	500	250	250	324 (Nr. 2)	
9311.1012/800/3		3000					350	547								2879
9311.1013/800/4		4000					350	647								3879
9311.1014/800/5	5000	4200	450	647	4879	II	8 × Ø20	600	700	300	300	508 (Nr. 4)				
9311.1015/1000/2	1000	2000	4200	3300	3265	300	447	1879	II	4 × Ø20	425	500	250	250	324 (Nr. 2)	
9311.1016/1000/3		3000					350	547								2879
9311.1017/1000/4		4000					350	647								3879
9311.1018/1000/5	5000	4200	450	647	4879	II	8 × Ø20	600	700	300	300	508 (Nr. 4)				

# Slewing pillar crane GISKB aluminium hollow profile

Lifting capacity up to 500 kg

## Standard version

- Pillar primed light grey RAL 7035
- Jib arm aluminium hollow profile
- Slewing range 270° stepless (manually)
- Trolley with smoothly running plastic load wheels
- Traction limit for trolley
- With anchorage for minimum C20/C25 concrete strength

## Options:

- Coating of pillar upon request or hot-dip galvanised
- Power supply; trailing cable, c-rail or conductor line with main switch (see page 18)
- Mounting options can be found on page 19
- Special solutions can be found on page 19
- Construction heights and jib lengths can be adapted individually to customer's needs.
- GIS electric chain hoist

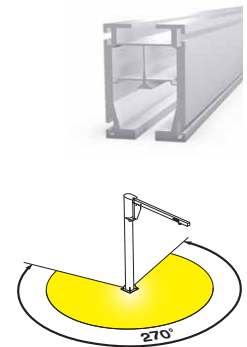
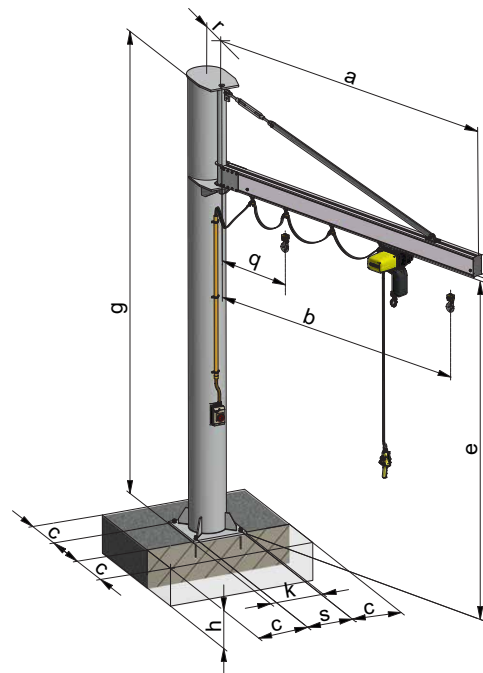

Part number	Capacity kg	Jib arm a mm	Height g mm	f mm	e mm	r mm	q mm	b mm	GISKB ALU	Base plate drill holes mm	s mm	k mm	Minimum edge distance c mm	Min. foundation thickness h mm	Pillar Ø mm						
9311.2000/125/2	125	2040	3800	3300	3279	265	458	1885	M	4 × Ø20	300	400	200	160	273 (Nr. 1)						
9311.2001/125/3		3040					558	2885													
9311.2003/125/4		4040					658	3885													
9311.2006/125/5		5050	4200			300	668	4895	L	4 × Ø20	425	500	250			250	324 (Nr. 2)				
9311.2008/125/6		6050					768	5895													
9311.2000/160/2		2040					458	1885													
9311.2001/160/3	3040	558	2885	M	4 × Ø20	300	400	200	160	273 (Nr. 1)											
9311.2003/160/4	4040	658	3885																		
9311.2006/160/5	5050	4200	300								668	4895	L	4 × Ø20	425	500	250	250	324 (Nr. 2)		
9311.2008/160/6	6050			768	5895																
9311.2000/200/2	2040			458	1885																
9311.2001/200/3	3040	558	2885	M	4 × Ø20	300	400	200			160	273 (Nr. 1)									
9311.2004/200/4	4050	658	3895																		
9311.2006/200/5	5050	4200	300						668	4895			L	4 × Ø20	425	500	250	250	324 (Nr. 2)		
9311.2008/200/6	6050			768	5895																
9311.2000/250/2	2040			458	1885																
9311.2001/250/3	3040	558	2885	M	4 × Ø20	300	400	200	160	273 (Nr. 1)											
9311.2004/250/4	4050	658	3895																		
9311.2006/250/5	5050	4200	300								668	4890	L	4 × Ø20	425	500	250	250	324 (Nr. 2)		
9311.2009/250/6	6050			350	768	5895	6 × Ø20	500			600	407 (Nr. 3)									
9311.2000/320/2	2040			458	1885																
9311.2001/320/3	3040	558	2885	M	4 × Ø20	300	400	200			160	273 (Nr. 1)									
9311.2004/320/4	4050	658	3895																		
9311.2006/320/5	5050	4200	300						668	4895			L	4 × Ø20	425	500	250	250	324 (Nr. 2)		
9311.2009/320/6	6050			350	768	5895	6 × Ø20	500	600	407 (Nr. 3)											
9311.2000/400/2	2040			458	1885																
9311.2002/400/3	3050	568	2895	M	4 × Ø20	300	400	200	160	273 (Nr. 1)											
9311.2005/400/4	4050	668	3895																		
9311.2007/400/5	5050	4200	350								668	4895	L	6 × Ø20	500	600	250	250	407 (Nr. 3)		
9311.2009/400/6	6050			768	5895																
9311.2000/500/2	2040			458	1885																
9311.2002/500/3	3050	568	2895	M	4 × Ø20	300	400	200			160	273 (Nr. 1)									
9311.2005/500/4	4050	668	3895																		
9311.2007/500/5	5050	4200	350						668	4895			L	6 × Ø20	500	600	250	250	407 (Nr. 3)		
9311.2010/500/6	6050			450	768	5895	8 × Ø20	600	700	300										300	508 (Nr. 4)

# Articulated slewing pillar crane GSD-TR steel pipe profile

Lifting capacity up to 250 kg

## Standard version

Articulated pillar-mounted slewing jib crane with maximum slewing range  
 Suitable for eccentric load handling with GIS handy telescope model  
 Pillar and jib primed light grey RAL 7035  
 Slewing range up to 270° (inner), respectively up to 330° (outer)  
 Jib length 2.6 m, longer jibs on request  
 With anchorage for minimum C20/C25 concrete strength

## Options:

Coating upon request or hot-dip galvanised  
 Power supply; trailing cable, c-rail or conductor line with main switch  
 With brake on internal and external joint  
 Mounting options can be found on page 19  
 Special solutions can be found on page 19  
 Construction height can be adapted to individual requirements.  
 GIS handy telescope model

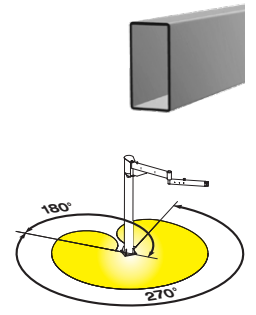
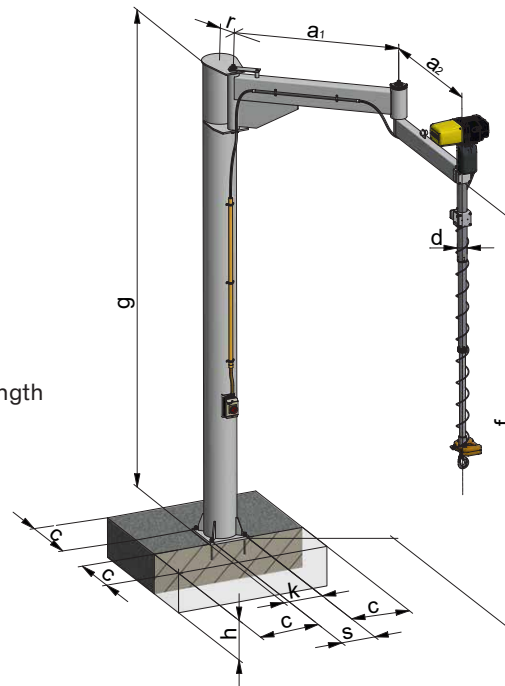

Part number	Capacity kg	Jib arm a1/a2 mm	Height g mm	f mm	r mm	Base plate drill holes mm	s mm	k mm	d Ø mm	Minimum edge distance c mm	Min. foundation thickness h mm	Pillar Ø mm
9311.3102.2	250	1400/1200	3400	2969	265	4 × Ø20	300	350	80	200	160	273 (Nr. 1)

# Slewing pillar crane IPE steel profile

Lifting capacity up to 1000 kg

## Standard version

- Pillar primed light grey RAL 7035
- Jib IPE steel profile
- Slewing range up to 270° stepless (manually)
- Rubber buffers mounted to the end of the jib
- With anchorage for minimum C20/C25 concrete strength

## Options:

- Coating upon request or hot-dip galvanised
- Power supply; trailing cable, c-rail or conductor line with main switch (see page 18)
- Mounting options can be found on page 19
- Special solutions can be found on page 19
- Construction heights and jib lengths can be adapted to individual requirements.
- GIS electric chain hoist with manual or motorised trolley

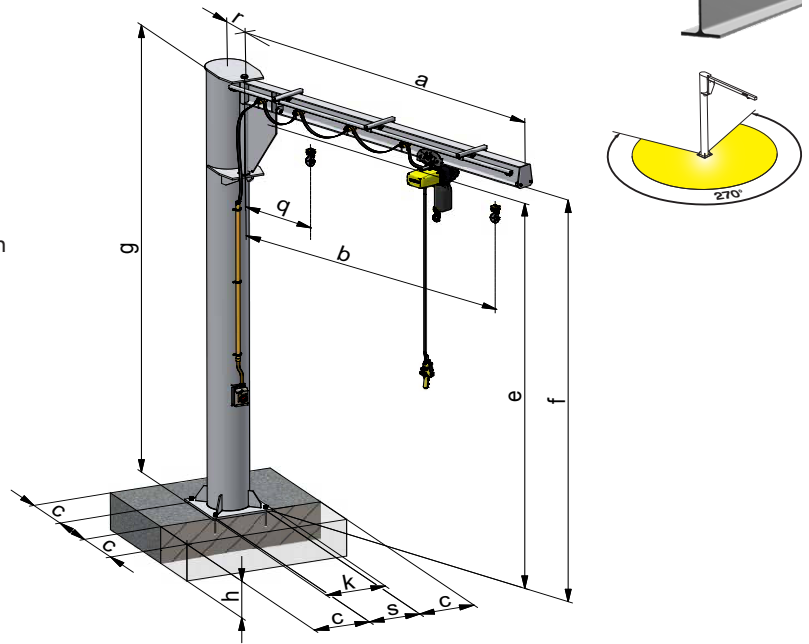

Part number	Capacity kg	Jib arm a mm	Height g mm	f mm	e mm	r mm	q mm	b mm	IPE	Flange mm	Base plate drill holes mm	s mm	k mm	Minimum edge distance c mm	Min. foundation thickness h mm	Pillar Ø mm
9311.1400/125/2	125	2000	3800	3612	3571	265	482	1860	160	82	4 × Ø20	300	400	200	160	273 (Nr. 1)
9311.1401/125/3		3000		3592	3552			2860	180	91						
9311.1402/125/4		4000		3860	180			91								
9311.1403/125/5	5000	4200	3992	3952	300	546	4860	240	120	4 × Ø20	425	500	250	250	324 (Nr. 2)	
9311.1400/160/2	160	2000	3800	3612	3571	265	482	1860	160	82	4 × Ø20	300	400	200	160	273 (Nr. 1)
9311.1401/160/3		3000		3592	3552			2860	180	91						
9311.1402/160/4		4000		3860	180			91								
9311.1404/160/5	5000	4200	3992	3953	300	546	4860	240	120	4 × Ø20	425	500	250	250	324 (Nr. 2)	
9311.1400/200/2	200	2000	3800	3612	3571	265	482	1860	160	82	4 × Ø20	300	400	200	160	273 (Nr. 1)
9311.1401/200/3		3000		3592	3552			2860	180	91						
9311.1405/200/4		4000		3992	3952			3860	180	91						
9311.1404/200/5	5000	4200	3932	3893	300	546	4860	240	120	4 × Ø20	425	500	250	250	324 (Nr. 2)	
9311.1400/250/2	250	2000	3800	3612	3571	265	482	1860	160	82	4 × Ø20	300	400	200	160	273 (Nr. 1)
9311.1401/250/3		3000		3592	3552			2860	180	91						
9311.1406/250/4		4000		3952	3913			3860	220	110						
9311.1404/250/5	5000	4200	3932	3893	300	546	4860	240	120	4 × Ø20	425	500	250	250	324 (Nr. 2)	
9311.1400/320/2	320	2000	3800	3612	3571	265	482	1860	160	82	4 × Ø20	300	400	200	160	273 (Nr. 1)
9311.1407/320/3		3000		3572	3532			2860	200	100						
9311.1406/320/4		4000		3952	3913			3860	220	110						
9311.1408/320/5	5000	4200	3932	3893	350	546	4860	240	120	6 × Ø20	500	600	250	250	407 (Nr. 3)	
9311.1400/400/2	400	2000	3800	3612	3571	265	482	1860	160	82	4 × Ø20	300	400	200	160	273 (Nr. 1)
9311.1409/400/3		3000		3972	3932			2860	200	100						
9311.1410/400/4		4000		3952	3913			3860	220	110						
9311.1411/400/5	5000	4200	3872	3835	350	546	4860	300	150	6 × Ø20	500	600	250	250	407 (Nr. 3)	
9311.1412/500/2	500	2000	3800	3592	3552	265	482	1860	180	91	4 × Ø20	300	400	200	160	273 (Nr. 1)
9311.1409/500/3		3000		3972	3932			2860	200	100						
9311.1410/500/4		4000		3952	3913			3860	220	110						
9311.1411/500/5	5000	4200	3872	3835	350	546	4860	300	150	6 × Ø20	500	600	250	250	407 (Nr. 3)	
9311.1413/630/2	630	2000	4200	3972	3932	350	546	1860	200	100	4 × Ø20	425	500	250	250	324 (Nr. 2)
9311.1414/630/3		3000		3932	3893			2860	240	120						
9311.1415/630/4		4000		3932	3893			3860	240	120						
9311.1416/630/5	5000	4200	3872	3835	450	546	4860	300	150	8 × Ø20	600	700	300	300	508 (Nr. 4)	
9311.1413/800/2	800	2000	4200	3972	3932	350	546	1860	200	100	4 × Ø20	425	500	250	250	324 (Nr. 2)
9311.1417/800/3		3000		3932	3893			2860	240	120						
9311.1418/800/4		4000		3932	3893			3860	240	120						
9311.1416/800/5	5000	4200	3872	3835	450	546	4860	300	150	8 × Ø20	600	700	300	300	508 (Nr. 4)	
9311.1419/1000/2	1000	2000	4200	3932	3893	350	546	1860	240	120	4 × Ø20	425	500	250	250	324 (Nr. 2)
9311.1417/1000/3		3000		3932	3893			2860	240	120						
9311.1420/1000/4		4000		3872	3835			3860	300	150						
9311.1421/1000/5	5000	4200	3842	3806	450	546	4860	330	160	8 × Ø20	600	700	300	300	508 (Nr. 4)	

# Slewing wall crane GISKB steel hollow profile

Lifting capacity up to 1000 kg

## Standard version

Console and jib arm primed light grey RAL 7035  
 Slewing range 180°/ 270° stepless (manually)  
 Trolley with smoothly running plastic load wheels  
 Travel limit stop for trolley  
 With anchorage for minimum C20/C25 concrete strength

## Options:

Coating upon request or hot-dip galvanised  
 Power supply; trailing cable, c-rail or conductor line with main switch (see page 18)  
 Electric travel movements  
 Mounting options can be found on page 19  
 Special solutions can be found on page 19  
 Construction heights and jib arm length can be adapted to customer's requirements.  
 GIS electric chain hoist

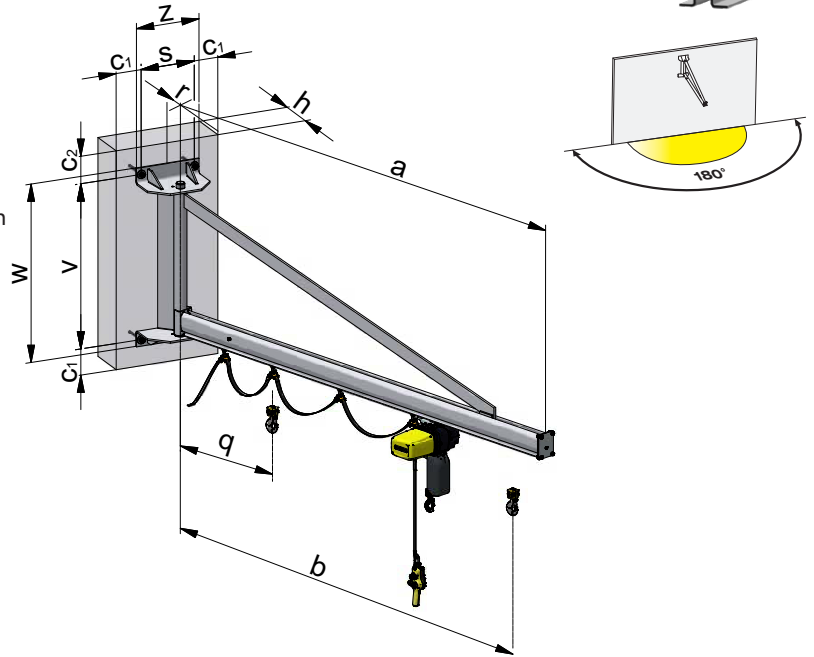

Part number	Capacity kg	Jib arm a mm	s mm	v mm	w mm	z mm	r mm	b mm	q mm	GISKB	Installation sleeves drill holes mm	Minimum edge distance c1/c2 mm	Min. wall thickness h mm
9311.1019/125/2	125	2000	240	621	703	300	160	1890	424	I	4 × Ø27 (Nr. 1)	250/400	200
9311.1020/125/3		3000						2890	524				
9311.1021/125/4		4000						3890	624				
9311.1025/125/5		5000						4879	647				
9311.1022/125/2		2000						1890	424				
9311.1023/125/3	3000	2890	524										
9311.1024/125/4	4000	3890	624										
9311.1025/125/5	5000	4879	647										
9311.1022/200/2	2000	1890	424	I	4 × Ø27 (Nr. 1)	250/400	200						
9311.1023/200/3	3000	2890	524										
9311.1024/200/4	4000	3879	647										
9311.1025/200/5	5000	4879	647										
9311.1022/250/2	2000	1890	424					II	4 × Ø30 (Nr. 2)	400/500	250		
9311.1023/250/3	3000	2890	524										
9311.1024/250/4	4000	3879	647										
9311.1025/250/5	5000	4879	647										
9311.1022/320/2	2000	1890	424	I	4 × Ø27 (Nr. 1)	250/400	200						
9311.1023/320/3	3000	2890	524										
9311.1024/320/4	4000	3879	647										
9311.1025/320/5	5000	4879	647										
9311.1026/400/2	2000	1770	424					II	4 × Ø30 (Nr. 2)	400/500	250		
9311.1027/400/3	3000	2879	547										
9311.1028/400/4	4000	3879	647										
9311.1029/400/5	5000	4879	647										
9311.1026/500/2	2000	1770	424	I	4 × Ø27 (Nr. 1)	250/400	200						
9311.1027/500/3	3000	2879	547										
9311.1028/500/4	4000	3879	647										
9311.1029/500/5	5000	4879	647										
9311.1026/630/2	2000	1879	447					II	4 × Ø30 (Nr. 2)	400/500	250		
9311.1027/630/3	3000	2879	547										
9311.1028/630/4	4000	3879	647										
9311.1033/630/5	5000	4879	647										
9311.1030/800/2	2000	1879	447	II	4 × Ø30 (Nr. 2)	450/700	300						
9311.1031/800/3	3000	2879	547										
9311.1032/800/4	4000	3879	647										
9311.1033/800/5	5000	4879	647										
9311.1034/1000/2	2000	1879	447					II	4 × Ø30 (Nr. 2)	400/500	250		
9311.1035/1000/3	3000	2879	547										
9311.1036/1000/4	4000	3879	647										
9311.1037/1000/5	5000	4879	647										



# Slewing wall crane GISKB aluminium hollow profile

Lifting capacity up to 500 kg



## Standard version

- Console primed light grey RAL 7035
- Aluminium profile jib arm
- Slewing range 180° / 270° stepless (manually)
- Trolley with smoothly running plastic load wheels
- Travel limit stop for trolley
- With anchorage for minimum C20/C25 concrete strength

## Options:

- Coating of console upon request or hot-dip galvanised
- Power supply; trailing cable, c-rail or conductor line with main switch (see page 18)
- Mounting options can be found on page 19
- Special solutions can be found on page 19
- Construction heights and jib arm length can be adapted to customer's requirements.
- GIS electric chain hoist

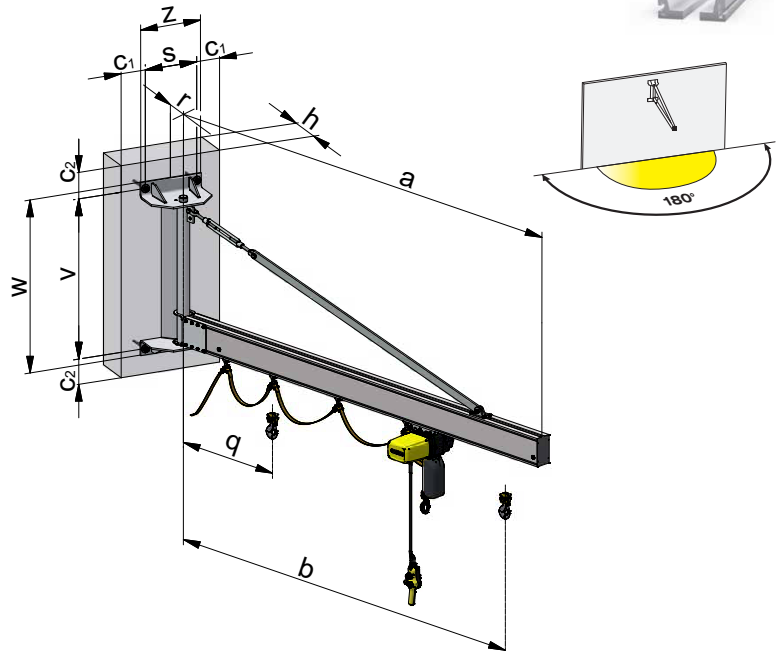

Part number	Capacity kg	Jib arm a mm	s mm	v mm	w mm	z mm	r mm	b mm	q mm	GISKB ALU	Installation sleeves drill holes mm	Minimum edge distance c1/c2 mm	Min. wall thickness h mm	
9311.2020/125/2	125	2040	240	621	703	300	160	1885	458	M	4 × Ø27 (Nr. 1)	250/400	200	
9311.2021/125/3		3040						2885	558					
9311.2023/125/4		4040						3885	658					
9311.2025/125/5		340	5050	1021	1103	400	185	4895	668	L	4 × Ø30 (Nr. 2)	400/500	250	
9311.2026/125/6			6050					5895	768					
9311.2020/160/2			2040					1885	458					
9311.2021/160/3	160	3040	240	621	703	300	160	2885	558	M	4 × Ø27 (Nr. 1)	250/400	200	
9311.2023/160/4		4040						3885	658					
9311.2025/160/5		5050						4895	668					
9311.2026/160/6		6050	5895	768										
9311.2020/200/2		200	2040	240	621	703	300	160	1885	458	M	4 × Ø27 (Nr. 1)	250/400	200
9311.2021/200/3			3040						2885	558				
9311.2024/200/4	4050		3895						568					
9311.2025/200/5	340		5050	1021	1103	400	185	4895	668	L	4 × Ø30 (Nr. 2)	400/500	250	
9311.2026/200/6			6050					5895	768					
9311.2020/250/2			2040					1885	458					
9311.2021/250/3	250	3040	240	621	703	300	160	2885	558	M	4 × Ø27 (Nr. 1)	250/400	200	
9311.2024/250/4		4050						3895	568					
9311.2025/250/5		5050						4895	668					
9311.2026/250/6		6050	5895	768										
9311.2020/320/2		320	2040	240	621	703	300	160	1885	458	M	4 × Ø27 (Nr. 1)	250/400	200
9311.2021/320/3			3040						2885	558				
9311.2024/320/4	4050		3895						568					
9311.2025/320/5	340		5050	1021	1103	400	185	4895	668	L	4 × Ø30 (Nr. 2)	400/500	250	
9311.2026/320/6			6050					5895	768					
9311.2020/400/2			2040					1885	458					
9311.2022/400/3	400	3050	240	621	703	300	160	2895	468	M	4 × Ø27 (Nr. 1)	250/400	200	
9311.2024/400/4		4050						3895	568					
9311.2025/400/5		5050						4895	668					
9311.2026/400/6		6050	5895	768										
9311.2020/500/2		500	2040	240	621	703	300	160	1885	458	M	4 × Ø27 (Nr. 1)	250/400	200
9311.2022/500/3			3050						2895	468				
9311.2024/500/4	4050		3895						568					
9311.2025/500/5	340		5050	1021	1103	400	185	4895	668	L	4 × Ø30 (Nr. 2)	400/500	250	
9311.2026/500/6			6050					5895	768					

# Slewing wall crane GWD-TR steel pipe profile

Lifting capacity up to 250 kg

## Standard version

Articulated wall-mounted slewing jib crane with maximum slewing range  
 Suitable for eccentric load handling with GIS handy telescope model  
 Console and jib primed light grey RAL 7035  
 Slewing range up to 180° (inner), respectively up to 330° (outer)  
 With anchorage for minimum C20/C25 concrete strength

## Options:

Coating upon request or hot-dip galvanised  
 Power supply with main switch  
 Mounting options can be found on page 19  
 Special solutions can be found on page 19  
 Construction height can be adapted to customer's requirements.  
 GIS handy telescope model

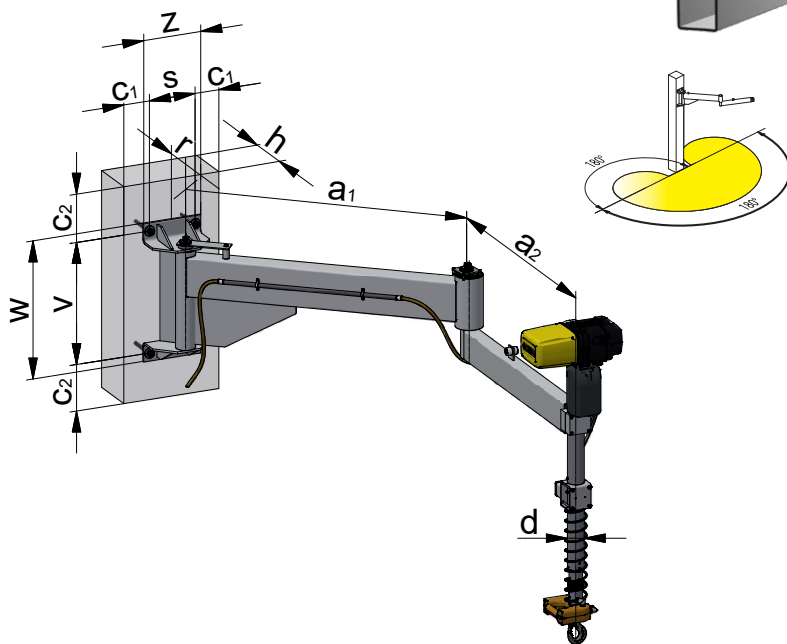

Part number	Capacity kg	Jib arm a1/a2 mm	r mm	z mm	s mm	v mm	w mm	Installation sleeves drill holes mm	d Ø mm	Minimum edge distance c1/c2 mm	Min. wall thickness h mm
9311.3103.2	250	1400/1200	160	300	240	621	703	4 × Ø27 (Nr. 1)	80	250/400	200

# Slewing wall crane IPE steel profile

Lifting capacity up to 1000 kg

## Standard version

Console and jib arm primed light grey RAL 7035  
 Slewing range 180°/ 270° stepless (manually)  
 Rubber buffers mounted to the end of the jib  
 With anchorage for minimum C20/C25 concrete strength

## Options:

Coating upon request or hot-dip galvanised  
 Power supply; trailing cable, c-rail or conductor line with main switch (see page 18)  
 Mounting options can be found on page 19  
 Special solutions can be found on page 19  
 Construction heights and jib arm length can be adapted to customer's requirements.  
 GIS electric chain hoist with manual or motorised trolley

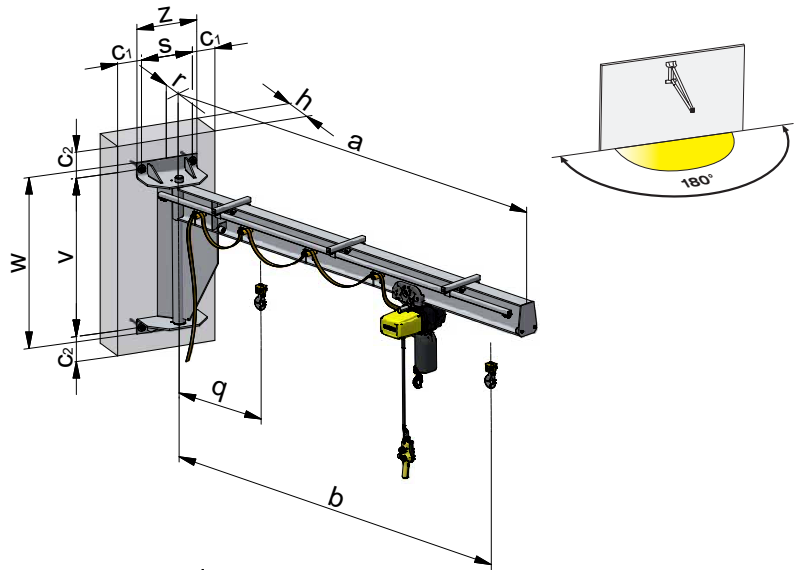

Part number	Capacity kg	Jib arm a mm	s mm	v mm	w mm	z mm	r mm	b mm	q mm	IPE	Flange mm	Installation sleeves drill holes mm	Minimum edge distance c1/c2 mm	Min. wall thickness h mm	
9311.1430/125/2	125	2000						1860		160	82				
9311.1434/125/3		3000	240	621	703	300	160	2860	482	180	91	4 × Ø27 (Nr. 1)	250/400	200	
9311.1438/125/4		4000						3860							
9311.1443/125/5		5000	340	1021	1103	400	185	4860	546			4 × Ø30 (Nr.2)	400/500	250	
9311.1430/160/2		2000							1860		160	82			
9311.1434/160/3	160	3000	240	621	703	300	160	2860	482	180	91	4 × Ø27 (Nr. 1)	250/400	200	
9311.1438/160/4		4000						3860							
9311.1444/160/5		5000	340	1021	1103	400	185	4860	546	240	120	4 × Ø30 (Nr.2)	400/500	250	
9311.1430/200/2		2000							1860		160	82			
9311.1434/200/3		3000	240	621	703	300	160	2890	482	180	91	4 × Ø27 (Nr. 1)	250/400	200	
9311.1439/200/4	200	4000						3860		200	100				
9311.1444/200/5		5000	340	1021	1103	400	185	4860	546	240	120	4 × Ø30 (Nr.2)	400/500	250	
9311.1430/250/2		2000							1860		160	82			
9311.1434/250/3		3000	240	621	703	300	160	2860	482	180	91	4 × Ø27 (Nr. 1)	250/400	200	
9311.1439/250/4		4000							3860		200	100			
9311.1444/250/5	250	5000	340	1021	1103	400	185	4860	546	240	120	4 × Ø30 (Nr.2)	400/500	250	
9311.1430/320/2		2000							1860		160	82			
9311.1435/320/3		3000	240	621	703	300	160	2860	482	200	100	4 × Ø27 (Nr. 1)	250/400	200	
9311.1440/320/4		4000							3860		220	110			
9311.1444/320/5		5000	340	1021	1103	400	185	4860	546	240	120	4 × Ø30 (Nr.2)	400/500	250	
9311.1430/400/2	400	2000	240	621	703	300	160	1860	482	160	82	4 × Ø27 (Nr. 1)	250/400	200	
9311.1436/400/3		3000						2860		200	100				
9311.1440/400/4		4000	340	1021	1103	400	185	3860	546	220	110	4 × Ø30 (Nr.2)	400/500	250	
9311.1445/400/5		5000						4860		300	150				
9311.1431/500/2		500	2000	240	621	703	300	160	1860	482	180	91	4 × Ø27 (Nr. 1)	250/400	200
9311.1436/500/3	3000							2860		200	100				
9311.1440/500/4	4000		340	1021	1103	400	185	3860	546	220	110	4 × Ø30 (Nr.2)	400/500	250	
9311.1445/500/5	5000							4860		300	150		450/700	300	
9311.1432/630/2	630		2000						1860		200	100			
9311.1436/630/3		3000						2860		240	120				
9311.1441/630/4		4000	340	1021	1103	400	185	3860	546	240	120	4 × Ø30 (Nr.2)	400/500	250	
9311.1445/630/5		5000						4860		300	150		450/700	300	
9311.1432/800/2		800	2000						1860		200	100			
9311.1437/800/3	3000							2860		240	120				
9311.1442/800/4	4000		340	1021	1103	400	185	3860	546	240	120	4 × Ø30 (Nr.2)	450/700	300	
9311.1445/800/5	5000							4860		300	150		500/700	350	
9311.1433/1000/2	1000		2000						1860		240	120			
9311.1437/1000/3		3000						2860		300	150				
9311.1442/1000/4		4000	340	1021	1103	400	185	3860	546	300	150	4 × Ø30 (Nr.2)	500/700	300	
9311.1446/1000/5		5000						4860		330	160		600/800	450	

## Ceiling-mounted slewing jib crane GISKB steel hollow profile

Lifting capacity up to 1000 kg

### Execution available optionally

Pillar and jib primed light grey RAL 7035  
Slewing range 270° stepless (manually)  
Trolley with smoothly running plastic load wheels  
Travel limit stop for trolley  
With anchorage for minimum C20/C25 concrete strength

### Options:

Coating upon request or hot-dip galvanised  
Power supply; trailing cable, c-rail or conductor line with main switch (see page 18)  
Mounting options can be found on page 19  
Special solutions can be found on page 19  
Construction heights and jib arm length can be adapted to customer's requirements.  
GIS electric chain hoist

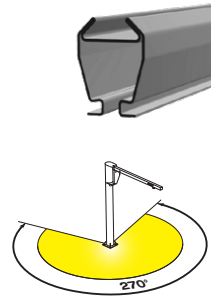
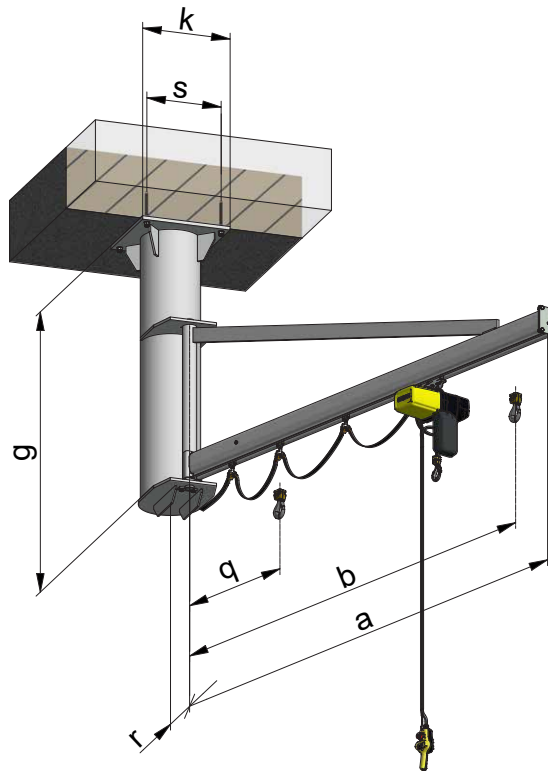

## Ceiling-mounted slewing jib crane GISKB aluminium hollow profile

Lifting capacity up to 500 kg

### Execution available optionally

Pillar primed light grey RAL 7035  
Aluminium profile jib arm  
Slewing range 270° stepless (manually)  
Trolley with smoothly running plastic load wheels  
Travel limit stop for trolley  
With anchorage for minimum C20/C25 concrete strength

### Options:

Coating of pillar upon request or hot-dip galvanised  
Power supply; trailing cable, c-rail or conductor line with main switch (see page 18)  
Mounting options can be found on page 19  
Special solutions can be found on page 19  
Construction heights and jib arm length can be adapted to customer's requirements.  
GIS electric chain hoist

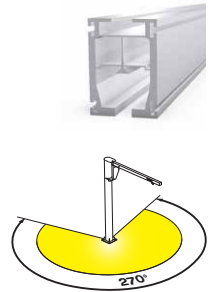
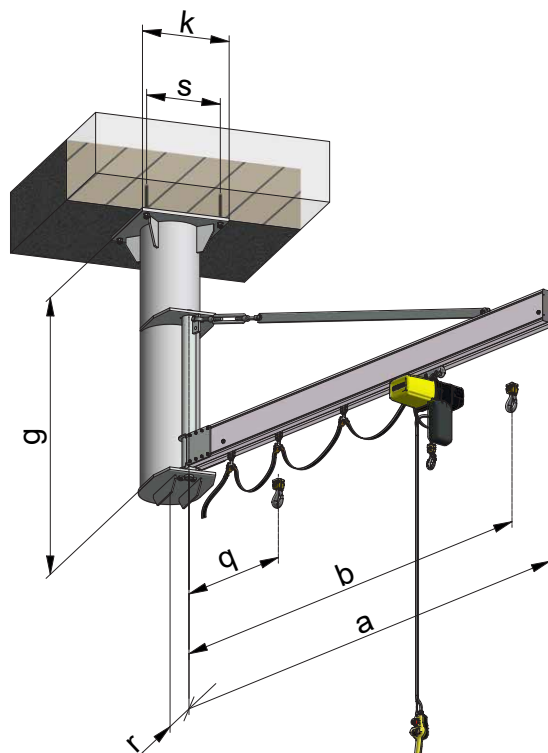

## Articulated ceiling-mounted slewing crane GSD-TR steel pipe profile

Lifting capacity up to 250 kg

### Execution available optionally

Pillar and jib primed light grey RAL 7035  
Slewing range 270° / 180° stepless (manually)  
With anchorage for minimum C20/C25 concrete strength

### Options:

Coating upon request or hot-dip galvanised  
Power supply with main switch  
Mounting options can be found on page 19  
Special solutions can be found on page 19  
Construction height can be adapted to customer's requirements.  
GIS handy telescope model

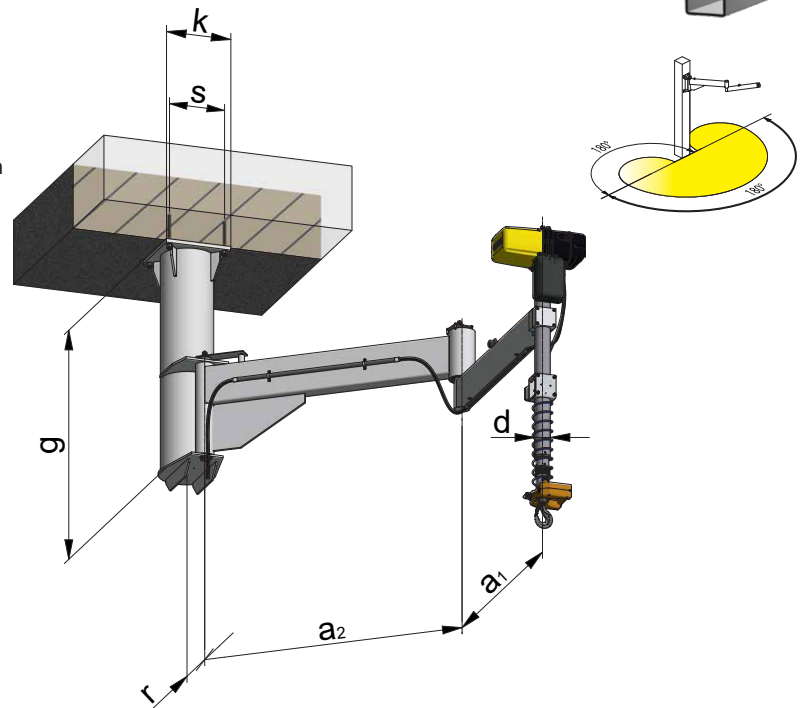

## Ceiling-mounted slewing jib crane IPE steel profile

Lifting capacity up to 1000 kg

### Execution available optionally

Pillar primed light grey RAL 7035  
IPE steel profile jib arm  
Slewing range 270° stepless (manually)  
Rubber buffers mounted to the end of the jib  
With anchorage for minimum C20/C25 concrete strength

### Options:

Coating of pillar upon request or hot-dip galvanised  
Power supply; trailing cable, c-rail or conductor line with main switch (see page 18)  
Mounting options can be found on page 19  
Special solutions can be found on page 19  
Construction heights and jib arm length can be adapted to customer's requirements.  
GIS GIS electric chain hoist with manual or motorised trolley

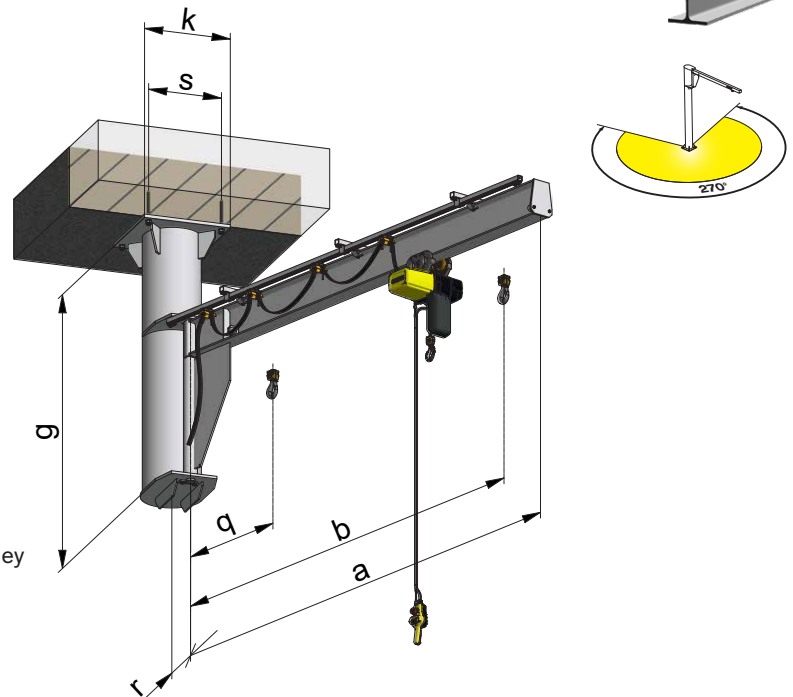

# Mobile slewing pillar cranes GSKB steel hollow profile

Lifting capacity up to 400 kg

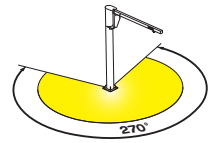
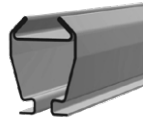

## Standard version

- Pillar and jib primed light grey RAL 7035
- Slewing range 270° stepless (manually)
- Trolley with smoothly running plastic load wheels
- Travel limit stop for trolley
- Including mounting material to concrete base

## Options:

- Coating upon request or hot-dip galvanised
- Power supply; trailing cable, c-rail or conductor line with main switch (see page 18)
- Mounting options can be found on page 19
- Special solutions can be found on page 19
- Construction heights and jib arm length can be adapted to customer's requirements.
- GIS electric chain hoist

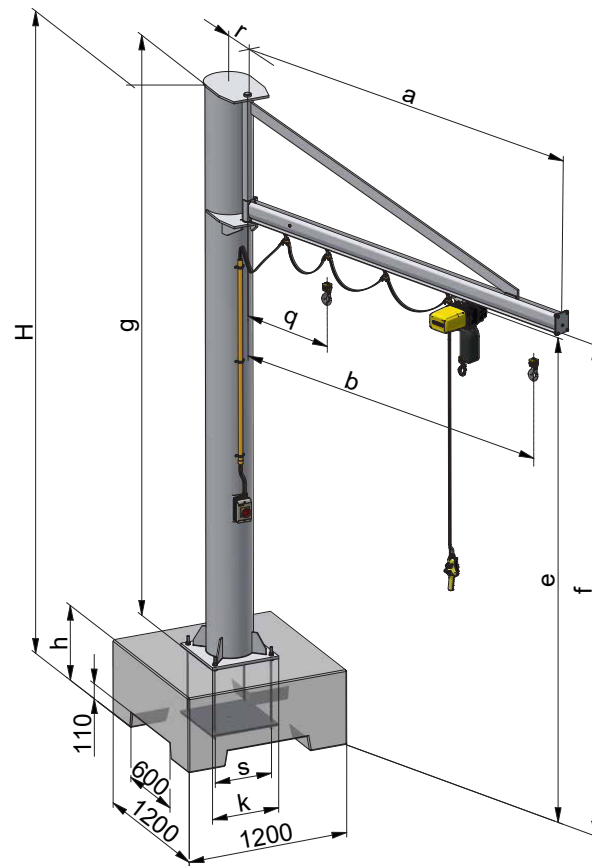

Capacity kg	Jib arm a mm	g mm	H mm	r mm	q mm	b mm	e mm	f mm	GSKB	Base plate drill holes mm	s mm	k mm	Pillar Ø mm	h mm	Total weight kg	Floor loading kg/m <sup>2</sup>
80	2000	3800	4160	265	424	1890	3625	3660	I	4 × Ø20	300	400	273 (Nr. 1)	330	~1100	~770
	3000				524	2890									~1100	~770
	4000				624	3890									~1150	~800
100	2000	3800	4160	265	424	1890	3625	3660	I	4 × Ø20	300	400	273 (Nr. 1)	330	~1100	~770
	3000				524	2890									~1100	~770
	4000				624	3890									~1900	~800
125	2000	3800	4160	265	424	1890	3625	3660	I	4 × Ø20	300	400	273 (Nr. 1)	330	~1100	~770
	3000				524	2890									~1100	~770
	4000				624	3890									~1900	~1320
160	2000	3800	4160	265	424	1890	3625	3660	I	4 × Ø20	300	400	273 (Nr. 1)	330	~1100	~770
	3000				524	2890									~1900	~1320
	4000				624	3890									~1100	~770
200	2000	3800	4160	265	424	1890	3625	3660	I	4 × Ø20	300	400	273 (Nr. 1)	330	~1100	~770
	3000				524	2890									~1900	~1320
	4000				624	3890									~1100	~770
250	2000	3800	4160	265	424	1890	3625	3660	I	4 × Ø20	300	400	273 (Nr. 1)	330	~1100	~770
320	2000	3800	4380	265	424	1890	3845	3880	I	4 × Ø20	300	400	273 (Nr. 1)	550	~1900	~770
400	2000	3800	4380	265	424	1890	3845	3880	I	4 × Ø20	300	400	273 (Nr. 1)	550	~1900	~1320

# Mobile slewing pillar cranes GISKB aluminium hollow profile

Lifting capacity up to 400 kg

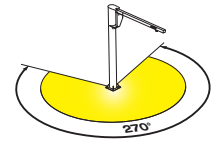

## Standard version

- Pillar primed light grey RAL 7035
- Aluminium profile jib arm
- Slewing range 270° stepless (manually)
- Trolley with smoothly running plastic load wheels
- Travel limit stop for trolley
- Including mounting material to concrete base

## Options:

- Coating of pillar upon request or hot-dip galvanised
- Power supply; trailing cable, c-rail or conductor line with main switch (see page 18)
- Mounting options can be found on page 19
- Special solutions can be found on page 19
- Construction heights and jib arm length can be adapted to customer's requirements.
- GIS electric chain hoist

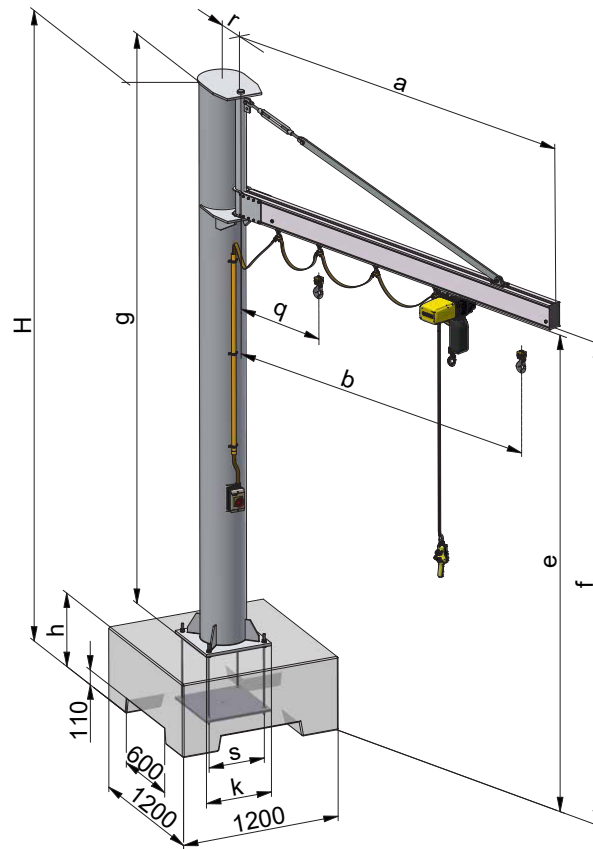

Capacity kg	Jib arm a mm	g mm	H mm	r mm	q mm	b mm	e mm	f mm	GISKB ALU	Base plate drill holes mm	s mm	k mm	Pillar Ø mm	h mm	Total weight kg	Floor loading kg/m <sup>2</sup>	
80	2030				458	1880									~1100	~770	
	3030	3800	4160	265	558	2880	3625	3660	M	4 × Ø20	300	400	273 (Nr. 1)	330	~1150	~800	
	4030				658	3880									~1150	~800	
100	2030		4160		458	1880		3625	3660						~1100	~770	
	3030	3800		265	558	2880		3625	3660	M	4 × Ø20	300	400	273 (Nr. 1)	330	~1150	~800
	4030		4380		658	3880	3845	3880						550	~1900	~800	
125	2030		4160		458	1880		3625	3660						~1100	~770	
	3030	3800		265	558	2880		3625	3660	M	4 × Ø20	300	400	273 (Nr. 1)	330	~1150	~800
	4030		4380		658	3880	3845	3880						550	~1900	~1320	
160	2030	3800	4160	265	458	1880	3625	3660	M	4 × Ø20	300	400	273 (Nr. 1)	330	~1100	~770	
	3030		4380		558	2880	3845	3880						550	~1900	~1320	
200	2030	3800	4160	265	458	1880	3625	3660	M	4 × Ø20	300	400	273 (Nr. 1)	330	~1100	~770	
	3030		4380		558	2880	3845	3880						550	~1900	~1320	
250	2030	3800	4160	265	458	1880	3625	3660	M	4 × Ø20	300	400	273 (Nr. 1)	330	~1100	~770	
320	2030	3800	4380	265	458	1880	3845	3880	M	4 × Ø20	300	400	273 (Nr. 1)	550	~1900	~770	
400	2030	3800	4380	265	458	1880	3845	3880	M	4 × Ø20	300	400	273 (Nr. 1)	550	~1900	~1320	

# Mobile articulated slewing pillar crane GSD-TR steel pipe profile

Lifting capacity up to 250 kg



## Standard version

Articulated pillar-mounted slewing jib crane with maximum slewing range  
 Suitable for eccentric load handling with GIS handy telescope model  
 Pillar and jib primed light grey RAL 7035  
 Slewing range up to 270° (inner), respectively up to 330° (outer)

### Options:

Coating upon request or hot-dip galvanised  
 Power supply with main switch  
 Further options can be found on page 19  
 Special solutions can be found on page 19  
 Construction height can be adapted to customer's requirements.  
 GIS handy telescope model

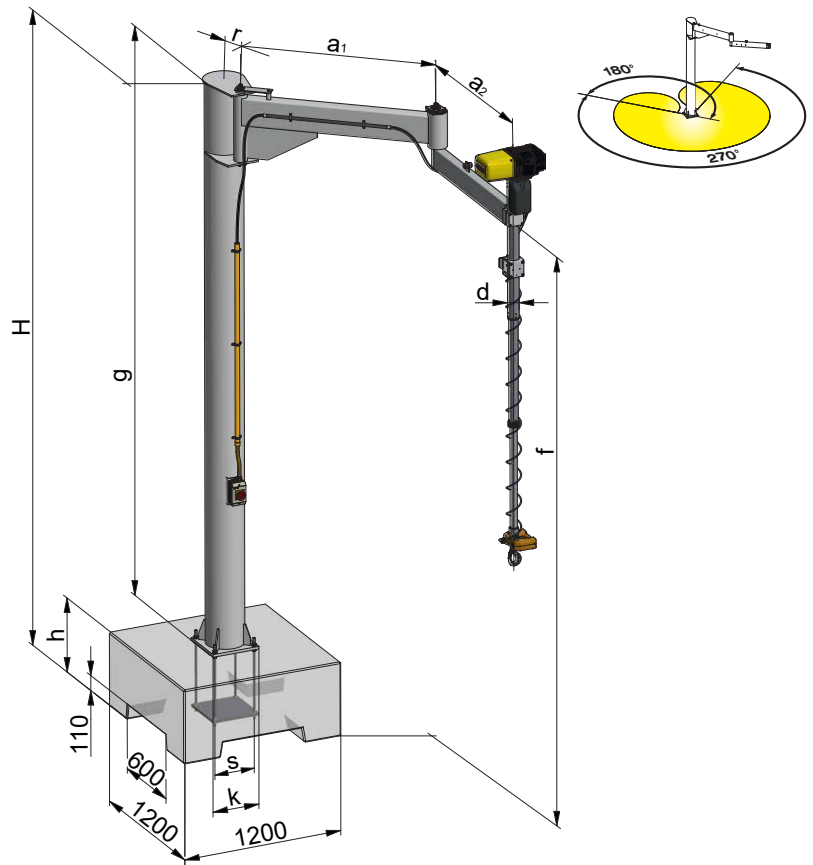

Capacity kg	Jib arm a1/a2 mm	g mm	H mm	r mm	f mm	Base plate drill holes mm	s mm	k mm	d Ø mm	Pillar Ø mm	h mm	Total weight kg	Floor loading kg/m2
250	1400/1200	3400	3950	265	2971	4 × Ø20	300	350	80	273 (Nr. 1)	550	~1900	~700



# Mobile slewing pillar crane IPE steel profile

Lifting capacity up to 400 kg

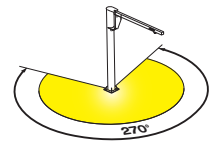

## Standard version

Pillar and jib primed light grey RAL 7035  
 Jib IPE steel profile  
 Slewing range 270° stepless (manually)  
 Rubber buffers mounted to the end of the jib  
 Including mounting material to concrete base

## Options:

Coating of pillar upon request or hot-dip galvanised  
 Power supply; trailing cable, c-rail or conductor line with main switch (see page 18)  
 Further options can be found on page 19  
 Special solutions can be found on page 19  
 Construction heights and jib arm length can be adapted to customer's requirements.  
 GIS GIS electric chain hoist with manual or motorised trolley

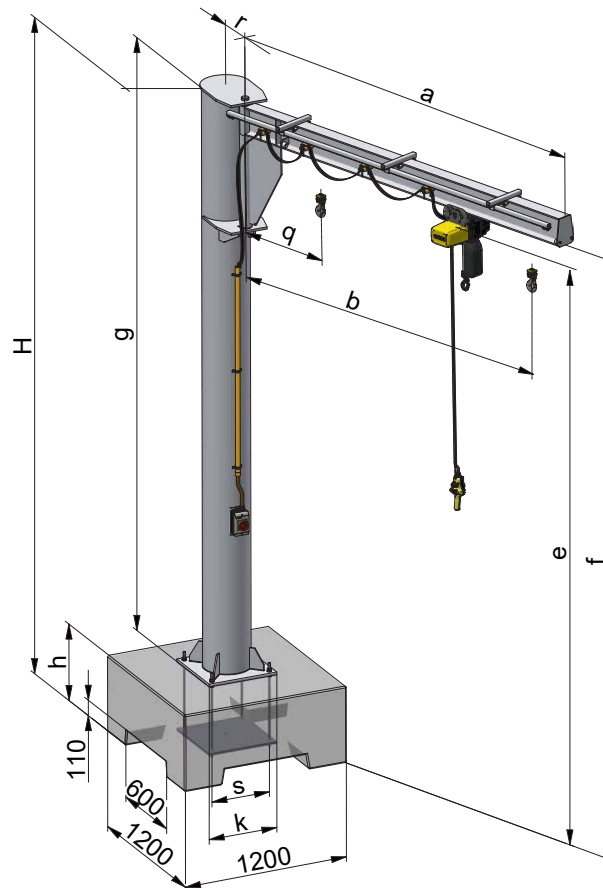

Capacity kg	a mm	g mm	H mm	r mm	q mm	b mm	e mm	f mm	IPE	Flange	Base plate drill holes mm	s mm	k mm	Pillar Ø mm	h mm	Total weight kg	Floor loading kg/m <sup>2</sup>
80	2000	3800	4160	265	482	1870	3930	3970	160	82	4 × Ø20	300	400	273 (Nr. 1)	330	~1100	~770
	3000					2870										~1150	~800
	4000					3870										~1150	~800
100	2000	3800	4160	265	482	1870	3930	3970	160	82	4 × Ø20	300	400	273 (Nr. 1)	330	~1100	~770
	3000		2870			~1150										~800	
	4000		4380			3870										4150	4190
125	2000	3800	4160	265	482	1870	3930	3970	160	82	4 × Ø20	300	400	273 (Nr. 1)	330	~1100	~770
	3000		2870			~1150										~800	
	4000		4380			3870										4150	4190
160	2000	3800	4160	265	482	1870	3930	3970	160	82	4 × Ø20	300	400	273 (Nr. 1)	330	~1100	~770
	3000		4380			2870										4150	4190
200	2000	3800	4160	265	482	1870	3930	3970	160	82	4 × Ø20	300	400	273 (Nr. 1)	330	~1100	~770
	3000		4380			2870										4150	4190
250	2000	3800	4160	265	482	1870	3930	3970	160	82	4 × Ø20	300	400	273 (Nr. 1)	330	~1100	~770
320	2000	3800	4380	265	482	1870	4150	4190	160	82	4 × Ø20	300	400	273 (Nr. 1)	550	~1900	~770
400	2000	3800	4380	265	482	1870	4150	4190	160	82	4 × Ø20	300	400	273 (Nr. 1)	550	~1900	~1320

# Power supply

## Trailing cable GISKB

### Standard version

- Cable carriage trolley inside profile
- For contaminated or humid environment
- Cost-efficient solution
- Suitable for outdoor use
- With main switch
- Option: equipped with compressed-air supply



## C-rail GISKB

### With trailing cable

- For contaminated or humid environment
- Using the entire travel range
- Suitable for outdoor use
- With main switch
- Option: equipped with compressed-air supply



## Conductor line GISKB

### External

- Space-saving (no hanging cables)
- Ideal approach dimensions
- Aesthetic solution
- With main switch
- Option: available with internal conductor line



## Trailing cable IPE

### Standard version

- Cable carriage trolley moving on profile
- For contaminated or humid environment
- Cost-efficient solution
- Suitable for outdoor use
- With main switch
- Option: equipped with compressed-air supply



## C-rail IPE

### With trailing cable

- For contaminated or humid environment
- Using the entire travel range
- Suitable for outdoor use
- With main switch
- Option: equipped with compressed-air supply

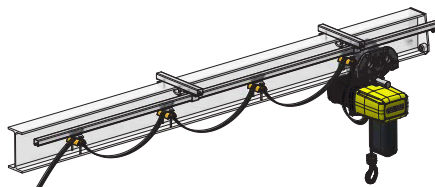

## Conductor line IPE

### External

- Space-saving (no hanging cables)
- Ideal approach dimensions
- Aesthetic solution
- With main switch



## Composite technology

The anchoring or dowelling technique is perfectly suitable for resilient concrete floors, walls or ceilings.

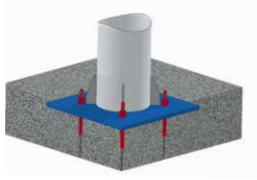

Anchoring technique for floor mounting

## Clasp

Ideal approach to the solution in case of concrete or steel pillars: frontally or around corners

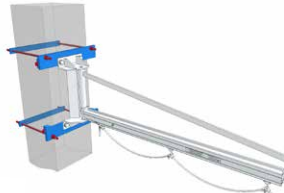

Classic clasp on frontal, rectangular pillar shape

## Counter plate

Distributes the force transmission in «sandwich»-load shared on a larger surface.

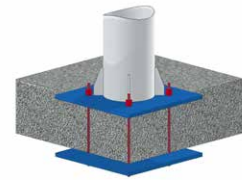

Floor plate for floor mounting

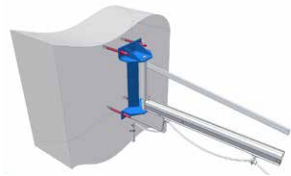

Dowelling technique for wall and ceiling mounting

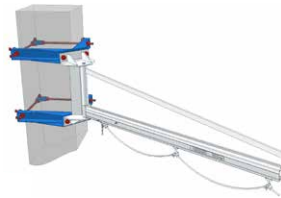

Fastening around corners

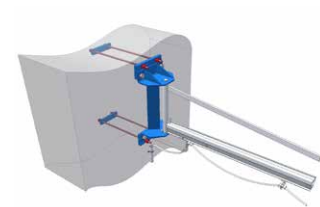

Wall mounting

## Special solutions

---

Higher lifting capacities up to 5000 kg

---

Electric slewing motion

---

Radio remote control for hoist and trolley

---

Frequency controlled hoist and trolley

---

Roving pendant, control switch independent of chain hoist

---

Slewing crane and chain hoists for outdoor use

---

Storm brake

---

Slewing limits

---

Special jib arm lengths

---

Double jib arm on a single pillar

---

Special pillar heights

---

Manual chain hoist

---

Console crane

---

Corrosion resistant version (food industry)

---

Jib arm with additional telescopic jib arm

---

Protection cover for chain hoist

---

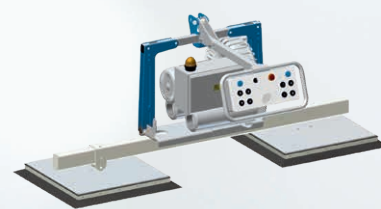
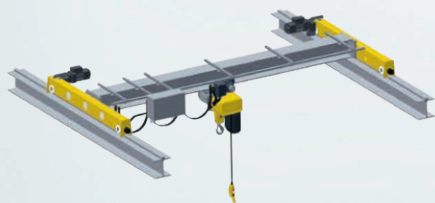

## Crane systems

GSKB steel crane construction kit for line-bound or all-round goods handling. GSKB aluminium crane system, slewing pillar and wall cranes for smooth handling of transport goods. Travelling cranes and slewing cranes made of steel profiles for heavier loads.

## Hoisting equipment

Over 60 years experience in the manufacture of electric chain hoists: robust, durable, reliable and highly resistant to wear. Simple maintenance. Various special versions for every application area. Wide range of accessories and options.

## Vacuum handling systems

GIS vacuum handling systems for the ergonomic and gentle handling of goods made of different materials like wood, glass, stone, metal or plastic. In combination with the appropriate crane system.

**GIS AG – the specialist for electric chain hoists and crane systems** Founding of the GIS AG in 1957 | With own subsidiaries in Germany, England and the United States | Development and production of electric chain hoists in Switzerland for over 60 years | Swiss manufacturer of complete crane systems inc. hoisting equipment and vacuum lifters | Certified to ISO 9001 since 1994 | Complete market services from project planning to installation, start-up and maintenance | International sales network with over 75 qualified partners worldwide

swiss lifting solutions

Certified to ISO 9001