

# ELECTRIC CHAIN HOISTS TROLLEYS INDUSTRY





**Ivan Muri, CEO** As a Swiss manufacturer with fully automated production, we are loyal to the location Switzerland. The high functionality, long life and robustness of our products help our customers to avoid operational interruptions which can cause high follow-on costs. With our own development and design department, we ensure long-term innovation power. Suppliers from Switzerland and its neighbour countries guarantee the reliability and quality we demand.

**Erich Widmer, Sales and Marketing Manager** From project planning to installation, we support our customers with advice and assistance. As a system supplier of complete crane systems, we can respond to specific customer demands. Our customers particularly value the variety of accessories and options. Our high product quality and readiness to deliver make us a reliable and competent partner worldwide.



# POWERFUL AND LONG-LASTING



Simple and easy to use – reliable and safe in operation – long-lasting and easy to maintain. GIS electric chain hoists have been developed and manufactured in Switzerland for more than 60 years. Hundreds of thousands of them are in operation worldwide – stationary or mobile.

---

Electric chain hoist GP - the endurance hoist

---



# GP



## Reliable and long-lasting

- 3 year warranty
- Made in Switzerland
- Chain safety factor minimum 8-times (DIN EN 14492 A5, ISO M5)
- Manganese phosphated profile steel chain with increased service life and improved dry-running properties
- Self-contained gearbox with permanent lubrication
- High safety in operation
- Low-wear DC-spring-loaded brake
- No sensitive electronics used
- Aluminium casing and cover
- Dry-running slipping clutch
- Area of application -15 °C to + 50 °C
- TÜV certified

## Easy to operate

- Low dead weight from 14 kg
- Compact housing with low headroom
- Modular in design
- Protection class IP65; suitable for outdoor use
- Geared limit switches with high accuracy in positioning of the highest and lowest hook position
- Ergonomic control switch with emergency stop
- 42 V low voltage control
- Quiet running with 3-step drive and helical gearing
- 2 speeds as standard
- Load hook rotated through 360°, with locking safety catch
- No special tools for maintenance needed
- Easy to maintain, wearing parts can be changed easily and quickly

## Customer specific

- Three- or single-phase power
- Worldwide operation and control voltages
- Direct control, special control, radio remote control, frequency inverter
- Special speeds
- Special versions such as synchronised electric chain hoist, low headroom version, corrosion resistant version, ATEX
- Eyebolt or hook suspension
- Lifting heights up to 200 m
- Hook path with upper and lower end position individually adjustable
- Temperature monitoring
- Operating data counter
- Extended temperature range
- Wide range of accessories and options (see pages 8 / 9)

## YOUR BENEFITS

The GP is simple in its structure and does not contain any sensitive electronics, which minimises the risk of operational interruptions. It is characterised by quiet running and is made for longevity whilst working hard. The ergonomic control switch with 42 V low voltage allows convenient and safe working. Maintenance is easy, quick and needs no special tools.

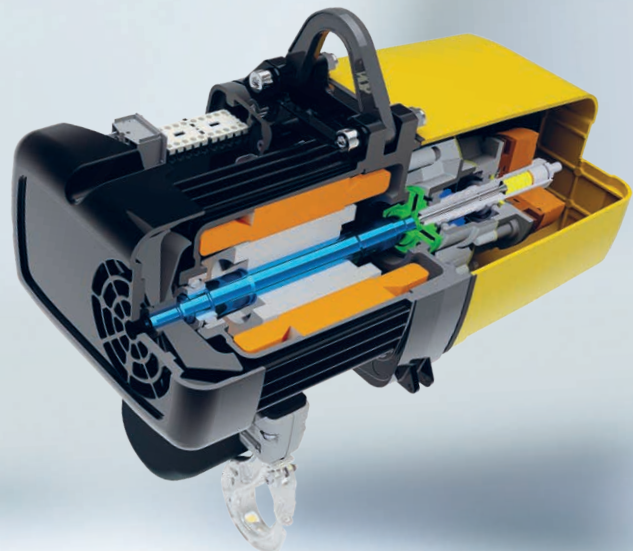

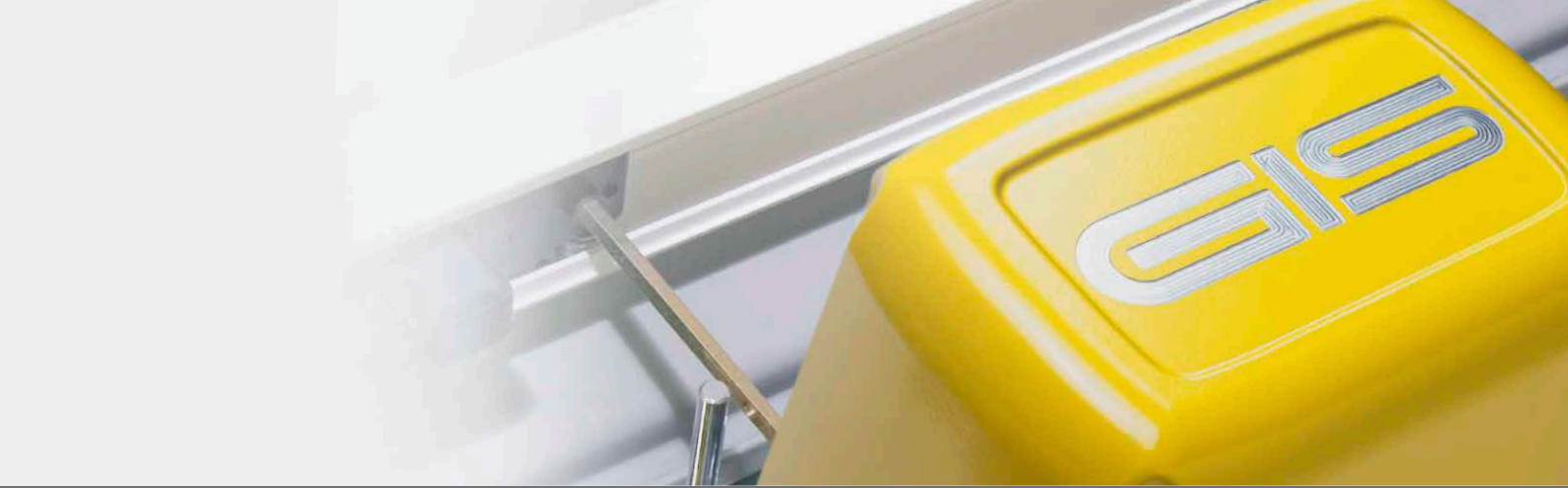

### Profile steel chain

The case hardened and manganese phosphated profile steel chain provides about 15 % more capacity at an identical nominal diameter when compared to the traditional round steel chain. The larger cross-sectional area reduces wear and increases the lifetime of the chain. The load hook with stable, guided hook latch and safety rubber buffer provides maximum safety.

### Control switch

The control switch fits comfortably in your hand and is ergonomically designed. It is robust, impact resistant, safe to operate and controlled by 42 V low voltage. Push buttons placed in parallel increase the ease of operation. The external strain relief protects the control cable.

### Polygonal connection

The inner part of the modularly designed chain hoist embodies real innovation. All shaft-hub connections are built to a polygonal design. This allows significantly faster disassembly and assembly during maintenance and thus reduces service costs. The service cost can be considerably reduced due to time savings.

### Protection class IP65

A feature of the hoist and the control switch is the protection class IP65. It is dust proof and protected against water jets. As it is compact and robust designed, the GP is best suited for dusty environments as well as for outdoor operation.



# USE



GIS electric chain hoists are used everywhere, where process safety of crane systems is important: in the hard three-shift operations in the automotives and other high production industries, in dusty or chemical aggressive environments, for outdoor use, for the entertainment industry or for extreme lifting heights in wind power plants. GIS electric chain hoists and trolleys are made to high standards. The safety factor of the load chain is at least 8 (DIN EN 14492 A5, ISO M5) which reduces wear and tear and increases the service life.

## VICTORINOX AG

Edwin Schuler, Ibach, Switzerland  
Head of Maintenance

GIS electric chain hoists and crane systems have been in use in our production plant for years, because we rely on the Swiss quality and proximity to the manufacturer and appreciate the corresponding expertise. We have already tested the new GP electric chain hoist as a prototype and it has fully lived up to our expectations. At a work place with a long service life and high switching frequency, it has proved itself throughout the entire test cycle and we can recommend it accordingly.







## Applications

Sewage treatment plants  
Agriculture / farming  
Automotive industry  
Construction industry  
Chemical and pharmaceutical  
Wire / cable / rubber processing  
Power supply / distribution  
Transportation and storage  
Glass processing industry  
Home technology / building automation  
Woodworking  
Municipal tasks

Kitchen building  
Plastics industry  
Paints and coatings  
Air transport / aviation  
Machine industry  
Medical technology  
Measuring and control technology  
Metal / steel processing  
Furniture / furnishings  
Food industry  
Surface technology  
Public transport

Paper / cardboard industry  
Transport and logistics  
Horology  
Entertainment industry  
Packaging  
Wind / hydroelectric power  
Oil industry  
Gas industry  
Shipyards / Shipbuilding



# ACCESSORIES & OPTIONS

## Standard version

Lifting capacities:
1-fall up to 4000 kg
2-fall up to 6300 kg
Standard voltages:
3 × 400 V / 50 Hz, 3 × 230 V / 50 Hz
1 × 115 V / 50 Hz, 1 × 230 V / 50 Hz
42 V low voltage control
1 phase motor: 1 speed
3 phase motor: 1 or 2 speeds
Protection class IP65
Eyebolt suspension
Standard lifting height 3 m
Minimum 8-fold chain safety factor (DIN EN 14492 A5, ISO M5)
Ergonomic control switch with emergency-stop
Control cable length 1.8 m
Control switch with external strain relief
Geared limit switches for highest and lowest hook position
Isolation class F (motor)
DC spring-loaded brake
Slipping clutch adjustable and not in the flow of forces
Detailed specifications according to technical datasheet

## Accessories and options

Direct control, special control
Radio remote control
Frequency inverter
Worldwide operating and control voltages
Special speeds available on request
Single handed operation with controls on the handle
Hook suspension
Safety load locking hook
Geared limit switch with two additional emergency stops
External limit switch / multiple limit switches
Parallel connection of multiple chain hoists
Operating data counter
Temperature monitoring to prevent the motor from overheating
Manual brake release / second brake
Chain container for various lifting heights
Gear grease for low temperature use / food industry
Slack chain shutdown
Load sensor for load measurement
Encoder for path measurement

## YOUR BENEFITS

For many applications, our standard versions provide a suitable lifting solution. A wide range of accessories and options is available. Extremely effective in repetitive goods handling is the single-handed operation of load management directly at the load. This allows quick and precise positioning of the load in left or right hand operation. As a handy chain or telescopic model this accessory can be retrofitted to a GIS electric chain hoist.





## Safety radio remote control

The 295 gram lightweight, very rugged handheld transmitter is powered by a rechargeable lithium ion battery and has a protection class of IP66. The receiver which is integrated in a stable housing has a protection class of IP65. With its certified STOP function the receiver meets the requirements of SIL 3 Performance Level PL e.



## Frequency inverter

Electric chain hoist, motorised trolley or the complete crane system can be operated using frequency inverters. The soft start ensures the accurate and gentle start and positioning of goods and minimises oscillating motion. The speeds and ramps for lifting and travelling can be programmed to suit the application.



## Operating data counter

The installation of an operating data counter gives the user additional safety during operation and can extend the life of the electric chain hoist when under-used. By analysing the operating hours and the number of circuits on a mobile reading device or a PC / laptop the optimum maintenance cycle can be set.

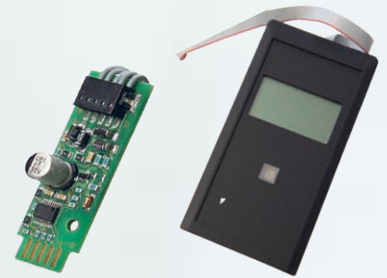

## Geared limit switch

With the integrated geared limit switch the upper and lower end position of the load hook can be set easily, precisely and are easily accessible. Optionally, to increase safety, two additional emergency stop contacts are available. High speed shutdown and external limit switch for high lifting heights are other options.

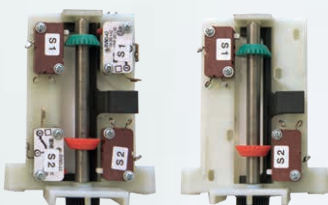

## Safety load locking hook

The mechanical interlocking of the hook lug of the 360° rotatable and 180° swivelling safety load hook secures the transported goods. The locking load hook closes automatically under load and must be manually unlocked for opening.



## Temperature monitoring

To secure the motor against overheating temperature monitoring is available. A thermocouple cuts off the power supply when reaching the given maximum temperature and prevents the motor from being damaged. This is extremely useful with long lifting heights or very high duty cycles.



# SERVICE & MAINTENANCE



The efficiency of an electric chain hoist should be considered throughout the whole product life cycle. The GP has low wear and is designed to last. Repair and maintenance is done simply and quickly which makes the chain hoist very economical to maintain. Its high reliability minimises the risk of production downtime and potentially high downtime costs. For our GP electric chain hoists we provide a 3 year warranty.

## YOUR BENEFITS

The GP series has an overall modular structure. Wearing parts are replaced in a simple manner. The electric chain hoist can be quickly disassembled and reassembled without special tools thanks to the polygonal connection. This saves time and costs, which both service technicians as well as customers appreciate. Our certified partners acquire their expertise during a qualified service training in our premises.

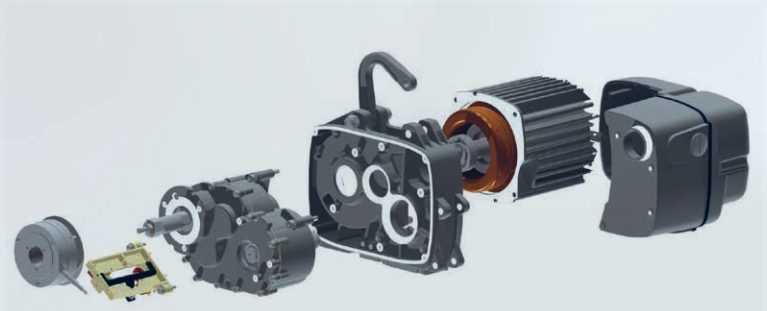

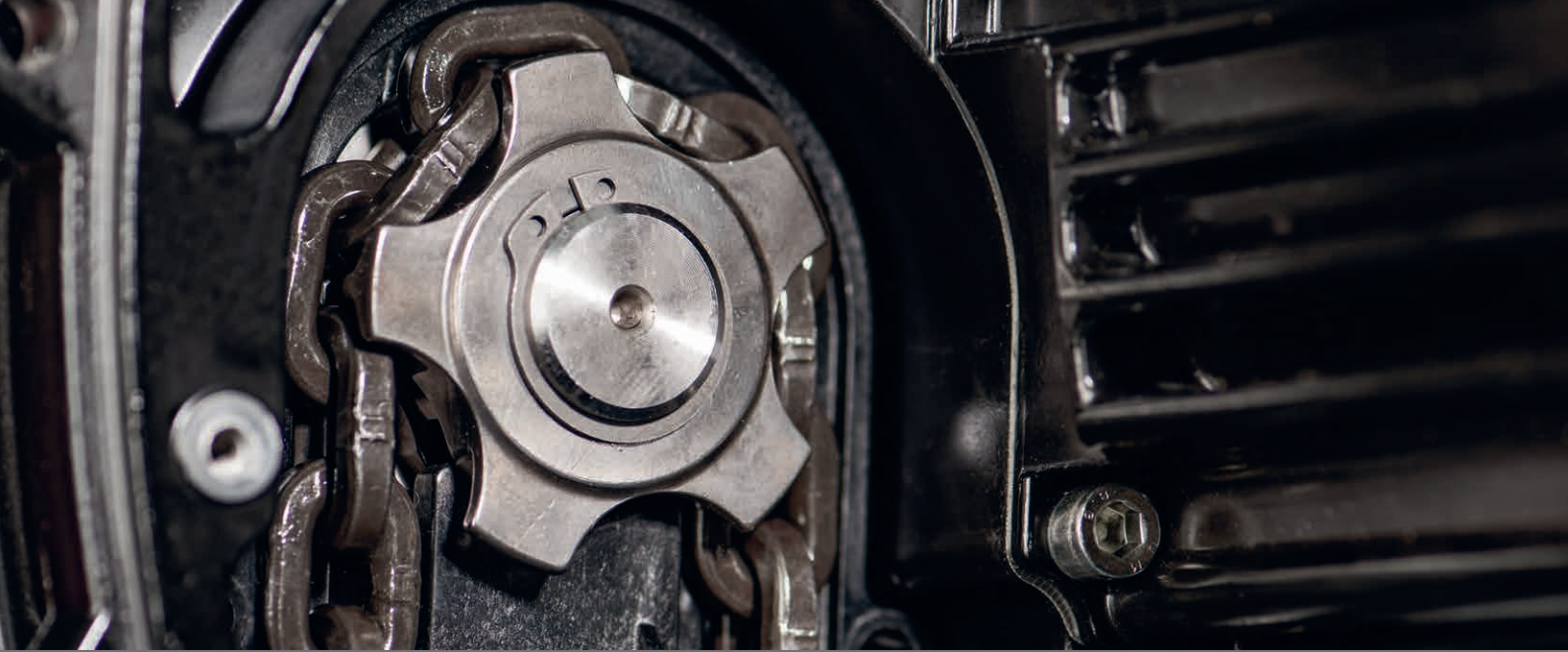

### Slipping clutch

The slipping clutch serves as an overload protection and protects the motor and the crane system against overloading. It is located in front of the brake, outside the flow of forces and runs dry with very low maintenance. The slipping clutch is easily accessible and adjustable.

### Chain guidance

Chain and chain guidance are wearing parts, which must be regularly checked and replaced if necessary. The chain guidance is easily and laterally disassembled within a few movements without complete dismantling of the chain hoist. This results in considerable time savings.

### Transmission

The 3-stage gear has helical gearing and lifetime permanent lubrication which provides smooth running and is maintenance free. Replacement is simple and clean, as the gearbox is self-contained and closed. The chain hoist can simply be converted to a different speed by changing the gear box.

### Spare parts

The modular design of the electric chain hoist means that wearing parts can quickly and easily be removed and replaced. This requires no special tools. We guarantee customers rapid availability of spare parts through our worldwide distribution partners.

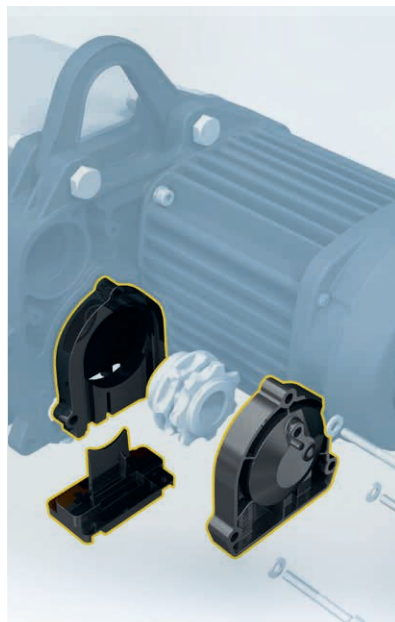
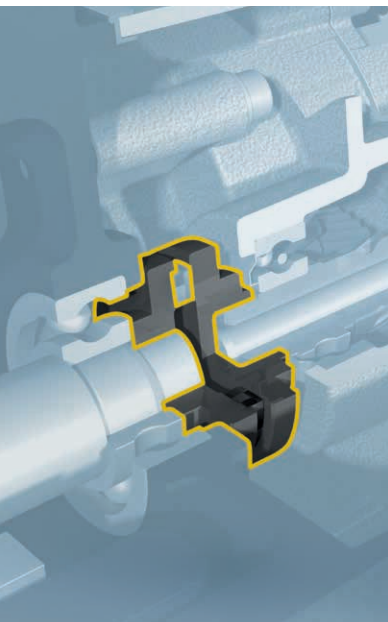



# SPECIAL PRODUCTS



For many industrial lifting applications standard GIS electric chain hoists offer the ideal solution. Depending on the complexity of the task and the conditions on site we offer GIS special products. Whether for the synchronous operation of two load hooks, for a corrosion resistant or explosion-proof version or an electric chain hoist with control unit on the load hook - we offer a customer- and application-specific solution for each lifting requirement.

## **GPK**

Lifting capacity up to 4000 kg

---

Low headroom version; the solution for especially low rooms

---

Obtaining room height using a sophisticated chain guide

---

Hook end positions adjustable by geared limit switch

---

Available with a lengthened frame for transporting large and bulky loads

---

1 or 2 lifting speeds

---

Automatic oil dispenser available for maintenance of the load chain

---

Perfect to combine with GISKB crane system or travelling crane

---

Option: with trolleys

---

Option: with frequency inverter

---

## **YOUR BENEFITS**

GIS electric chain hoists are suitable on account of their compactness and durability for installation in complete systems. Thanks to our own engineering department, we are able to optimally combine the devices with a crane system or a vacuum handling system, in order to be able to offer a lifting solution which is ideally adapted to the lifting task as well as to the operating space conditions.





### GPS

Lifting capacity up to  
2 × 2500 kg

Synchronised electric chain hoist for transportation of long and bulky loads

Precise parallel operation of both load paths  
2 electric chain hoists connected electrically and mechanically

With temperature monitoring

Hook end positions adjustable by geared limit switch

Distance between load hooks 0.7 - 5.0 m

Perfect to combine with GISKB suspended crane or travelling crane

Option: with trolleys

Option: with frequency inverter

Option: customised devices for load handling



### GPHK

Lifting capacity up to 500 kg

Handy chain model for quick and easy positioning of loads

Control of electric chain hoist and guidance of the load with one hand

Control unit with rocker switch for left- and right-handed operation

Hook end positions adjustable by geared limit switch

Perfect to combine with GISKB slewing or suspended crane

Option: handy kit for retrofitting of standard electric chain hoist

Option: with frequency inverter

Option: customised devices for load handling



### GPHT

Lifting capacity up to 250 kg

Handy telescope model for fast and accurate positioning of loads

Operation of electric chain hoist and simultaneous precise guidance of the load with one hand

Ideally suited for eccentric loads

Control unit with rocker switch for left- and right-handed operation

Hook end positions adjustable by geared limit switch

Perfect to combine with articulated slewing crane or GISKB suspended crane

Option: with frequency inverter

Option: customised devices for load handling

Option: with slack chain shutdown







### GP 1-Ph

Lifting capacity up to 2000 kg

Electric chain hoist in 1-phase version

Workshop use in the absence of 3-phase power supply, rental use, outdoor use

Standard voltages:  
1 x 115 V / 50 Hz  
1 x 230 V / 50 Hz

Speed 2, 4 or 8 m / min.

High duty cycle (DIN EN 14492 A5, ISO M5) at maximum load capacity

Protection class IP65

Option: temperature monitoring

Option: special voltages:  
1 x 115 V / 60 Hz  
1 x 230 V / 60 Hz

Option: 1-phase motorised trolleys



### GPR

Lifting capacity up to 1250 kg

Corrosion resistant electric chain hoist

For use in food, pharmaceutical or chemical industry, wastewater treatment plants, outdoor use

Housing cataphoresis coated

Stainless round steel chain

Suspension corrosion resistant

All parts in contact with the chain (equipping parts such as chain wheel, load hooks, screws) in corrosion resistant version

Protection class IP65

Special grease for food industry

Option: manual or motorised trolley in corrosion resistant version



### GP ATEX

Lifting capacity up to 6300 kg

Electric chain hoist explosion proof ATEX version

Dust-proof version GP D:  
Equipment group II, Equipment category 3  
Zone 22 (D)  
Temperature = <130 °C  
with temperature monitoring

Gas-proof version GP G:  
Equipment group II, Equipment category 3  
Zone 2 (G), 22 (D)  
Temperature class = T3  
with temperature monitoring  
operation interruption in the event of a pressure drop

Protection class IP65

Option: motorised trolley in ATEX version







### GP W

Lifting capacity up to 1000 kg

Electric chain hoist for wind turbines

Lifting speed up to 16 m/min.

Lifting height up to 200 m

Temperature monitoring with shutdown function of the motor in case of overheating

Automatic switching from high to low lifting speed shortly before the stroke end by geared limit switch

External limit switches for hook end positions

Tempered special chain

Option: with manual or motorised trolley

Option: chain container



### LP

Lifting capacity up to 6300 kg

Electric chain hoist for entertainment industry

Low dead weight

For stationary or mobile use

Quiet running due to 3-stage drive with helical gearing

Usable as stationary or as a climbing hoist without modification

Second brake without housing extension can be equipped or retrofitted

Direct control or contactor control

Protection class IP65 for outdoor use

KTL coating guarantees corrosion resistance and good mechanical protection

Versions D8, D8 Plus and C1 or depending on customer requirements



### GPFU

Lifting capacity up to 6300 kg

Electric chain hoist with frequency inverter

For applications with high switching frequency and shift operation

Lifting speed up to 9.6 m/min.

With soft start for precise and gentle positioning of the load

Transportation without overshooting and exact positioning of the load in combination with frequency-controlled motorised trolley

Speeds and ramps for lifting and travelling programmable adjusted to the application

Protection class IP65

Option: motorised trolley with frequency inverter

Option: load-dependent lifting



# TROLLEYS



GIS travel trolleys are simple in design and allow smooth transportation of loads up to 6300 kg on steel beams. The electric chain hoist serves as a lifting device. The travel movement, tailored to the load capacity and the local conditions is either manually or electrically driven. The integrated fall and climbing protection made of solid cast steel, as well as the intervention protection ensure maximum safety. Due to their good handling characteristics and their longevity, GIS trolleys are often used by our customers as components for end carriage of underslung travelling cranes.

## YOUR BENEFITS

Compared to the previous models, the GHF / GMF 1250 - 6300 trolleys offer a 25 % higher capacity. They are designed for maximum flexibility and longevity. The larger diameter of the load wheels, the helical gear parts and load wheels which can be matched to the beam surface ensure a longer service life and optimum running properties. The flange width is infinitely variable by means of a new type of adjustment system and can be fixed easily by using the a locking function. Optionally available support carrier rollers ensure smooth running in curves.





### GHF 500 K

Lifting capacity up to 500 kg

Manual trolley for steel beams

Manual or electric chain hoist moved manually

Glass fibre reinforced plastic rollers

Optimum ease of movement

Very quiet running

Side plates made of die-cast aluminium with fall and climbing protection

Low weight of only 2.5 kg

Galvanised support bolts

Flange width 50 - 149 mm

Minimum bend radius 1200 mm



### GHF 1250 – 6300

Lifting capacity up to 6300 kg

Manual trolley for steel beams

Manual or electric chain hoist moved manually

Load wheels made of cast iron, with ball bearings

Side plates made of cast iron with fall and climbing protection

GHF 1250/2500 with 1 support bolt  
GHF 5000/6300 with 2 support bolts

Galvanised support bolts

Flange width infinitely variable

Option: parking brake for GHF 1250

Options and accessories for side plates, load wheels and support bolts according to page 18

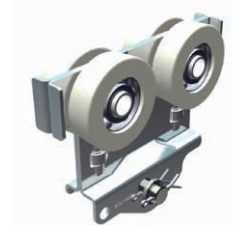

### GISKB trolleys

Lifting capacity up to 800 kg

Manual trolley for GISKB hollow steel profiles

For manual movement of manual or electric chain hoist or as longitudinal trolley for GISKB crane bridges

Optimum ease of movement

Very quiet running due to plastic load wheels and lateral guide rollers

Galvanised steel construction

Option: steel load wheels

Option: rubber buffers as collision protection

Option: combination of 2 trolleys with a traverse to achieve a capacity of 1600 kg





# MOTORISED TROLLEYS

## Standard version

Lifting capacities:  
up to 6300 kg

Standard voltages:  
3 × 400 V / 50 Hz, 3 × 230 V / 50 Hz  
1 × 115 V / 50 Hz, 1 × 230 V / 50 Hz

Control 42 V low voltage

1 phase motor: 1 speed

3 phase motor: 1 or 2 speeds

Protection class IP54

Side plates and load wheels made of cast iron

Load wheels for flat running surfaces (flat profile beam)

Flange width infinitely variable

Galvanised support bolts

Fall and climbing protection

4 button ergonomic control switch with emergency stop

Control cable length 2 m

Control switch with external strain relief

Isolation class F (motor)

DC spring-loaded brake

Detailed specifications according to technical data sheet

## Accessories and options

Direct control, special control

Radio remote control

Festoon mounted pendant control box

Frequency inverter

Worldwide operating and control voltages

Special speeds available on request

Travel limit switch 1 or 2 stages

Carrier rollers for cornering

Convex load wheels made of cast iron

Plastic load wheels

Load wheels made of steel or stainless steel

Trolley in corrosion resistant version

Trolleys in ATEX version

Special support bolts for special flange widths

Gear grease for low temperature use / food industry

Temperature monitoring to prevent the motor from overheating

Protection class IP65

Counterweight modularly expandable

## YOUR BENEFITS

GIS motorised trolleys offer one or two speeds of max. 30 metres per minute. For moving without oscillation and precise positioning of the load, the trolleys can be equipped with frequency inverters. The motorised trolleys are operated, tailored to the respective application, by means of a control switch on the trolley, a control switch independent of the trolley (festoon mounted pendant control box) or radio remote control.





## GMF 1250 – 6300

Lifting capacity up to 6300 kg

Motorised trolley for steel beams

Long-lasting and low wearing

Speeds 12, 12/4 or 24/6 m/min.

Side plates made of cast iron with fall and climbing protection

GMF 1250/2500 with 1 support bolt

GMF 4000/5000/6300 with 2 support bolts

GMF 5000/6300 with 2 motors

Galvanised support bolts

Flange width infinitely variable

Protection type IP54

Modular expandable counterweight

Control box with easily accessible connections

Accessories and options according to page 18

## GMF 1250 – 6300 FU

Lifting capacity up to 6300 kg

Motorised trolley with frequency inverter for steel beams

Long-lasting and low wear

Speed 3.6 - 30 m/min.

Transport without oscillation and precise positioning of loads

Soft start for high demands

2 speeds are programmable: for starting / positioning and travel

Basic specifications as GMF 1250 - 6300

Accessories and options according to page 18

## SAKB with FU

Lifting capacity up to 1600 kg

Electric tug with frequency inverter for moving GISKB trolleys

Very quiet running due to plastic load wheels

2 speeds and ramps adjustable 3 - 35 m/min.

Soft start and stop

Transport without oscillation and precise positioning of loads

DC spring-loaded brake

Protection type IP55

Option: travel limit switch

Option: radio remote control



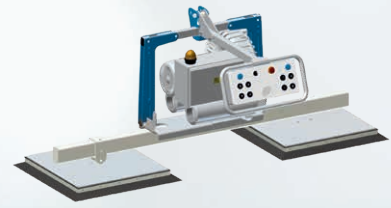
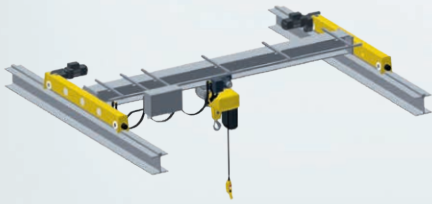

## Crane systems

GISKB steel crane construction kit for line-bound or all-round goods handling. GISKB aluminium crane system, slewing pillar and wall cranes for smooth handling of transport goods. Travelling cranes and slewing cranes made of steel profiles for heavier loads.

## Hoisting equipment

Over 60 years experience in the manufacture of electric chain hoists: robust, durable, reliable and highly resistant to wear. Simple maintenance. Various special versions for every application area. Wide range of accessories and options.

## Vacuum handling systems

GIS vacuum handling systems for the ergonomic and gentle handling of goods made of different materials like wood, glass, stone, metal or plastic. In combination with the appropriate crane system.

**GIS AG – the specialist for electric chain hoists and crane systems** Founding of the GIS AG in 1957 | With own subsidiaries in Germany, England and the United States | Development and production of electric chain hoists in Switzerland for over 60 years | Swiss manufacturer of complete crane systems inc. hoisting equipment and vacuum lifters | Certified to ISO 9001 since 1994 | Complete market services from project planning to installation, start-up and maintenance | International sales network with over 75 qualified partners worldwide

swiss lifting solutions  
Certified to ISO 9001